

Multiport Analog IAD

SmartNode 4830 Series VoIP IAD



Multiport analog VoIP IAD with ADSL2+, G.SHDSL, or V.35/X.21 interface. The SmartNode 4830 Series connects up to 8 phone lines, VoIP, and Internet/VPN access across the integrated broadband WAN interface. Offering bundled voice, data, and VPN services, the SmartNode IAD delivers best-in-class VoIP quality for lowest cost networking.

Integrated WAN Access

ADSL2+, G.SHDSL**, T1/E1, V.35/X.21 WAN access options. Two 10/100 Ethernet ports. Access router with NAT, Firewall, PPPoE, DHCP, and DynDNS.

Full VoIP Protocol Support

SIPv2, H.323v4, T.38, fax & modem bypass, G.723, G.729, G.726, G.711, echo cancellation, silence compression, comfort noise, DTMF relay.

FXS, FXO, or Combinations

Up to 8 FXS ports connect to your standard telephone or PBX. 2 or 4 FXO ports allow local PSTN connections. Programmable call routing and switching.

Maximum Voice Quality

Advanced adaptive traffic management for maximum voice quality. Voice prioritization and DownStreamQoS™.

Management & Provisioning

Web-based management, SNMP, command line interface, and auto-provisioning for automated configuration & software upgrades.

Patton's SmartNode™ 4830 Series IADs let you add packet voice while providing access routing with native V.35/X.21 synchronous serial connection, G.SHDSL and ADSL2+ WAN access options. Add up to 8 phone lines and combine Internet and VPN access on a single PPP or Frame-Relay based access line for the new standard in toll-bypass, remote/branch office connectivity, and enhanced carrier services.

The SN4830 Series offers models with combinations of 2 to 8 analog FXS phone ports and 2 or 4 FXO ports. The Dual 10/100Base-T LAN ports can be used for LAN, IPsec VPN and DMZ connections. The integrated WAN port provides direct access to broadband networks (you choose between X.21/V.35, T1/E1, ADSL2+, and G.SHDSL). Like every SmartNode, the 4830 series supports the industry standard VoIP signaling protocols SIP, H.323, T.38 Fax-Relay, plus Fax and Modem-Bypass and is interoperable with leading Softswitches and VoIP services.

Quality of Service (QoS) features include advanced voice prioritization and traffic management. DownStreamQoS™ ensures voice without interruptions even over best-effort internet connections. Packet labeling according to 802.1p, TOS and DiffServ enable integration into managed QoS networks.

The SN4830 is the solution for service providers and network integrators looking for the seamless integration of analog phones and PBXs into converged VoIP-Data networks. It ensures easy setup and continuous trouble-free operation and cost effective deployment. The support of the leading VoIP signaling protocols ensures interoperability with third-party equipment and protects your investments for the future.

Visit www.patton.com for more information.



Special Rates Available
Call for Details

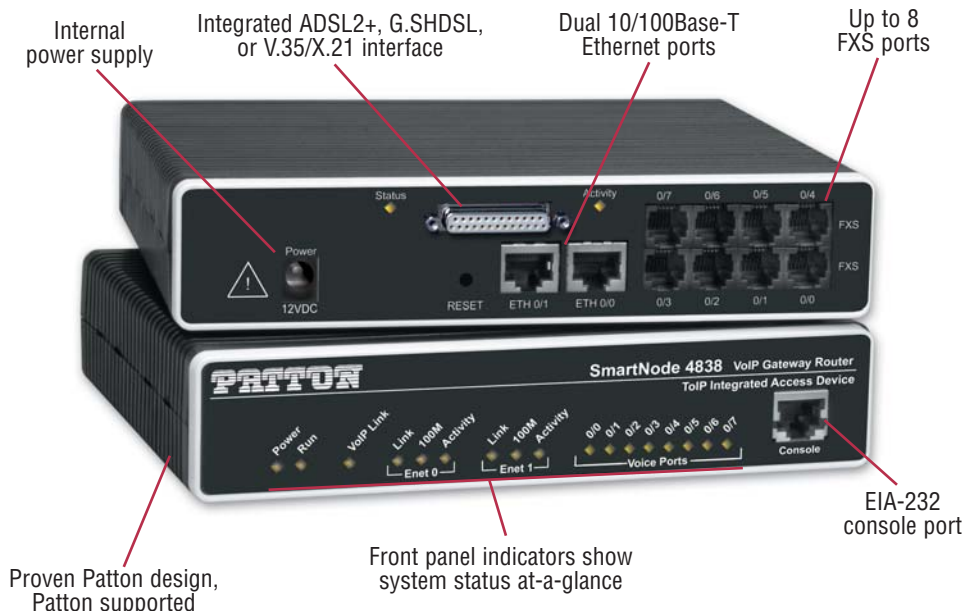

Application—Remote Office/Branch Office Voice Extension and Access

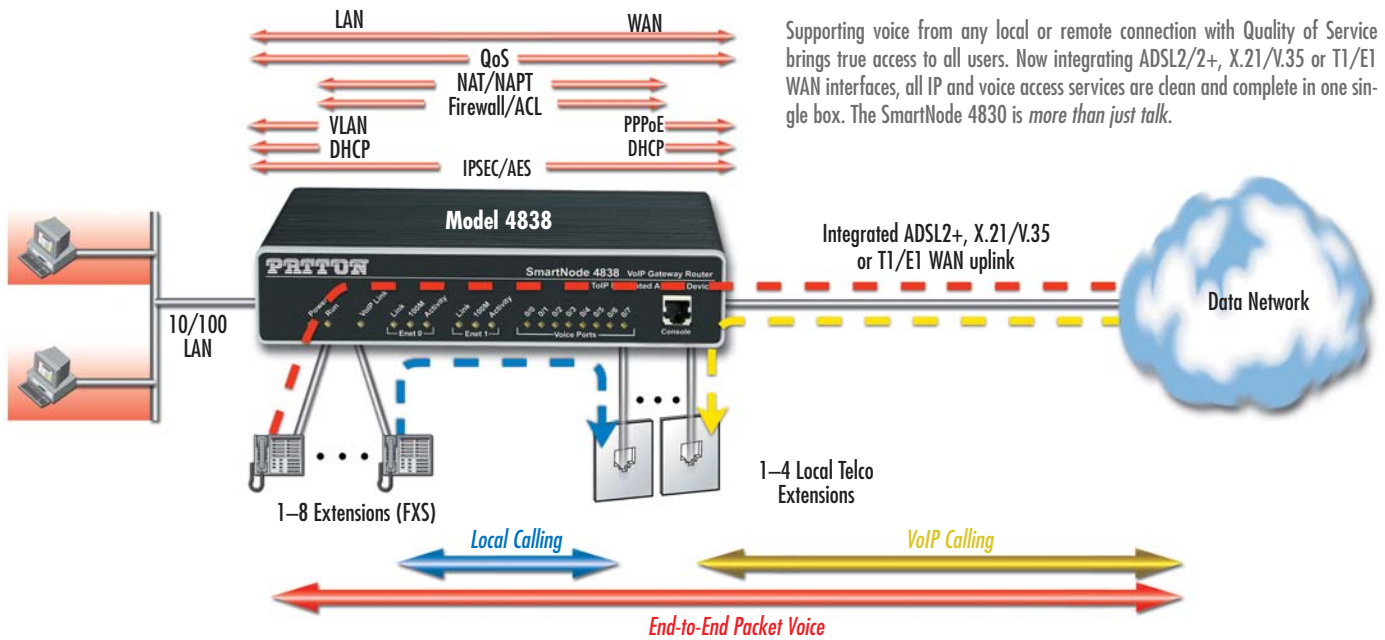

Supporting voice from any local or remote connection with Quality of Service brings true access to all users. Now integrating ADSL2+/2+, X.21/V.35 or T1/E1 WAN interfaces, all IP and voice access services are clean and complete in one single box. The SmartNode 4838 is *more than just talk*.

Specifications*

Voice Connectivity

2-wire Loopstart, RJ-11/12 • Short haul loop 1.1 km @3REN • EuroPOTS (ETSI EG201 188) • Programmable AC impedance, feeding, and ring voltage; On-Hook Voltage 29VDC • Caller-ID Type-1/2 FSK and ITU V.23/Bell 202 generation

IP Connectivity

Two 10/100 Ethernet ports • ADSL2+ (Annex A, B, I, J, L, M, U-R2 X.21/V.35; Frame Relay (8 PVCs); RFC1490, FRF.12 fragmentation; LMI, Q.933D, ANSI 617D, Gang of Four; PPP, PAP, CHAP, LCP, IPCP T1/E1; ITU-T G.703, ANSI T1.403; AMI, B8ZS, HDB3)

Voice Processing

G.711 A-Law/ μ -Law (64kbps) • G.726 (ADPCM 40, 32, 24, 16 kbps) • G.723.1 (5.3 or 6.3 kbps) • G.729ab (8kbps) •

G.168 echo cancellation • 8 simultaneous low-bandwidth voice or T.38 fax calls • DTMF detection and generation • Carrier tone detection and generation • Silence suppression and comfort noise • Configurable dejitter buffer • Configurable tones (dial, ringing, busy) • Configurable transmit packet length • RTP/RTCP (RFC 1889)

Fax and Modem Support

G.711 transparent fax • Fax over IP (FoIP) • T.38 Fax relay (9.6 k, 14.4 k)

Voice Signaling

SIPv2 • H.323v4 • SIP call transfer, redirect • Overlap or en-bloc dialing • DTMF in-band, out-of-band • Configurable tones

Call Routing & Services

Regular expression number matching • Regular expression number manipula-

tion • Least Cost Routing • Number blocking • Short-Dialing • Digit collection • Distribution-Groups and Hunt-Groups

IP Services

IPv4 router; RIPv1, v2 (RFC 1058 and 2453) • Programmable static routes • ICMP redirect (RFC 792); Packet fragmentation • DiffServ/ToS set or queue per header bits • Packet Policing discards excess traffic • 802.1p/Q VLAN support with 4096 IDs • IPsec AH & ESP Modes • Manual Key; IKE optional • AES/DES/3DES Encryption

Management

Industry standard CLI with local console (CRJ-45, RS-232) and remote Telnet access • TFTP configuration & firmware loading • SNMP v1 agent (MIB II and private MIB) • Built-in diag-

nostic tools (trace, debug) • Java™ Applet; HPOV Integration with NNM

Operating Environment

Temp.: 0–40°C
Humidity: 5–80% (non condensing)

System

CPU Motorola MPC859 @ 50 MHz • Memory 16MB SDRAM/4MB Flash • Power: 100–240 VAC (50/60 Hz) • Power dissipation: 4W

Compliance

EMC compliance: EN55022 and EN55024
Safety compliance: EN 50950
CE compliance
FCC Part 15 Class A

* Specifications subject to change without notice.

Model Information

- SN4832/JSX*/EUI: 2 Port FXS with integrated WAN
- SN4834/JSX*/EUI: 4 Port FXS with integrated WAN
- SN4836/JSX*/EUI: 6 Port FXS with integrated WAN
- SN4838/JSX*/EUI: 8 Port FXS with integrated WAN
- SN4834/2JS2JOX*/EUI: 2 FXS, 2 FXO with integrated WAN
- SN4836/4JS2JOX*/EUI: 4 FXS, 2 FXO with integrated WAN
- SN4832/JOX*/EUI: 2 FXO with integrated WAN
- SN4834/JOX*/EUI: 4 FXO with integrated WAN
- SN4838/4JS4JOX*/EUI: 4 FXS, 4 FXO with integrated WAN

Sync Serial Cables

- 1205-25M/35M: DB-25 male to M/34 male, for V.35 port
- 1205-25M/35F: DB-25 male to M/34 female, for V.35 port
- EMEM216006: DB-15 male to DB-15 male, for X.21 port

ADSL Splitters

- 5A-1: Single-port ADSL Splitter

Options & Accessories

- SNSW-VPN1: License key for IPsec VPN support (DES, 3DES, AES)

*x = Interface options: C=V.35 (DB-25F), D=X.21 (DB-15F), K=E1 (RJ-48C), T=T1 (RJ4-8C), Ay=ADSL (RJ-11), y=Annex: a=Annex A, b=Annex B, G=G.SHDSL (RJ-11)

** Call for availability.

PE-Inal Networks Private Ltd

An Associate of

PATTON
Electronics Co., USA

Old No. 14 and New No.6,
Brahadambal Road,
Nungambakkam High Road
Chennai: 600 034, India
Phone **+91 44 45490395/6/7**
Fax **+91 44 4549.0394**
Email **sales@patton.co.in**
Web **www.patton.co.in**

Patton-Inal Networks AG

PATTON
inal networks

Meriedweg 7
CH-3172 Niederwangen
Switzerland
Phone **+41 (31) 985 25 25**
Fax **+41 (31) 985 25 26**
E-mail **sales@inalp.com**
Web **www.inalp.com**

Patton Electronics Co.

PE PATTON
Electronics Co.

7622 Rickenbacker Drive
Gaithersburg, Maryland 20879
USA
Phone **+1 301 975 1000**
Fax **+1 301 869 9293**
E-mail **sales@patton.com**
Web **www.patton.com**

07MSN4830-DS4

Patton is a registered trademark and the terms SmartNode, DownStreamQoS, and SessionRouter are trademarks of Patton Electronics Company in the United States and other countries.